

MOTOR BRUSH Replacement

Motor Brush replacement requires substantial disassembly of the chassis. Proceed as follows:
 1) Remove Body and Cab as described above. Remove weights. Before proceeding, study the arrangement of the various electrical elements atop 707107 Lamp Bracket. This will facilitate reassembly later on.

2) Disengage Truck Wires 707313 from Contact Wires 707104.

3) Remove Fuel Tank 707213 by releasing its two forward latches. Slide Fuel Tank slightly forward to release the two rear latches. Removing Fuel Tank will expose Motor Mounting Screws 707113.

4) Remove the Screws. Motor, Saddles, Flywheels and Lamp Bracket 707107 will come away from the Mainframe as an assembly.

5) Slide off Rear Flywheel and Rear Saddle. Front Flywheel and Saddle needn't be removed.

6) Very carefully disengage the long 707104 contact wires from 707107 Lamp Bracket allowing lamp to be removed.

7) Straighten the phosphor-bronze Conductor/Retainers to a vertical position as shown in Fig. 1. and pull Lamp Bracket away from Motor.

8) Conductor/Retainers can now be unsnapped from the brass brush receptacles at the top and bottom of the motor. Brushes and Springs can now be removed for replacement.

IMPORTANT! The shorter Conductor/Retainer must be attached to the upper brush receptacle and the longer Conductor/Retainer to the lower brush receptacle and must be positioned as shown in Fig. 1. Reversing these positions will reverse connections with the long Contact Wires causing the engine to run in a direction opposite to NMRA Standards. To reassemble motor and chassis components, follow the above procedure in reverse.

HEADLAMP Replacement

1) Remove Body. No further disassembly is required.

2) Use fine tweezers and modeler's knife to gently disengage the very fine lamp wires.

3) Install new 707106 Lamp using simplified arrangement shown in Fig. 4. Just wedge the lamp wires under the phosphor-bronze Retainer/Conductor from the motor brushes.

FIG. 3

Motor Brush Replacement

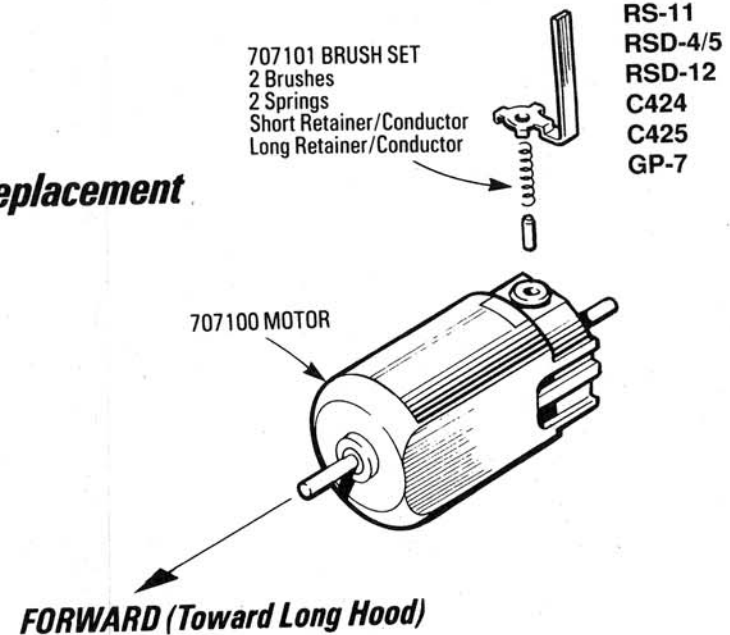

REFERENCE

- RS-1
- RS-3
- RS-11
- RSD-4/5
- RSD-12
- C424
- C425
- GP-7

FIG. 4

Simplified Lamp Wiring

