

N GE U25B DIESEL LOCO JAPAN

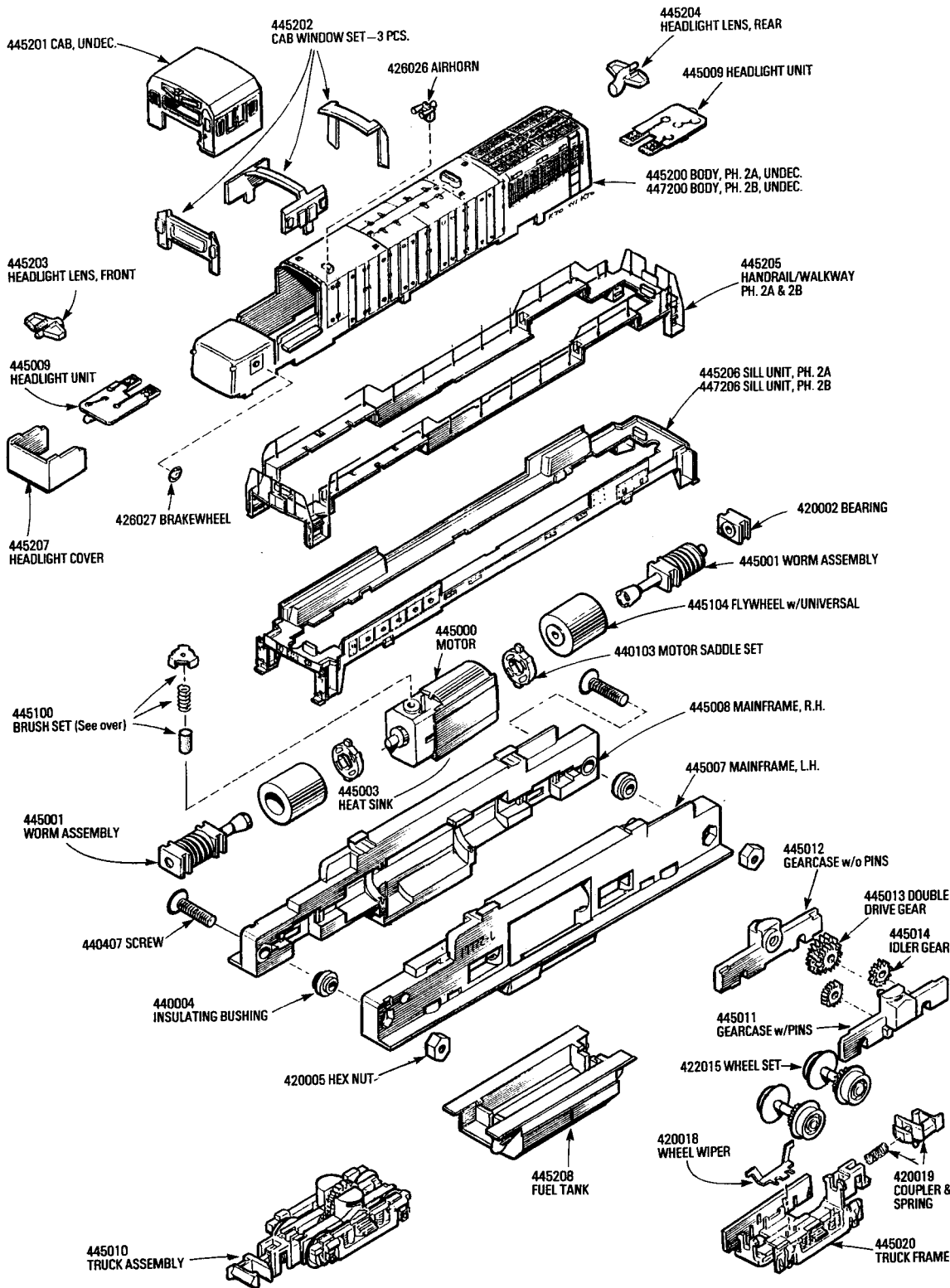

Mr. Roundhouse Superintendent:

The Atlas GE U25B Diesel has been carefully assembled and tested before leaving the factory. It will provide virtually maintenance-free service; however, normal wear from extended usage may necessitate occasional replacement of lamps and motor brushes.

Major disassembly should rarely be necessary and is *not recommended* for the novice. Only a person experienced in the repair of miniature locomotives should attempt dismantling the model as shown in the exploded perspective drawings and described in the text.

IMPORTANT

Before attempting any disassembly, all the instructions should be carefully read and the exploded perspectives studied thoroughly in order to become familiar with all parts of the model. It is not necessary to completely dismantle the chassis in order to remove or replace the trucks. See "Truck Replacement" below.

BODY Removal

- 1) Disengage handrails from holes in cab front and rear endwalls.
- 2) Remove body as follows: Grasp hood near the front corners and pull, *firmly*, upward. Cab may now be lifted away to allow removal of window glazing. Release side-windows first by pressing them inward with the top of a pencil then front and rear glazing will come out easily. Reverse above procedure to reinstall glazing. Remove fuel tank by pulling downward against its frontwall. Note that tanklatches are more widely spaced at the front end than at the rear.

CHASSIS Disassembly

- 1) Remove both Headlight Circuit Boards by sliding them away from the mainframe castings.
- 2) Lay the mainframe on its rightside and remove the screw at each end. Carefully lift away the Left Mainframe to expose chassis elements. Be careful not to lose the #420004 Insulating Bushings separating the mainframe castings at each end.

TRUCK Replacement

We recommend against attempting repairs to the trucks. Disassembly is relatively easy but reassembly is very difficult and requires a great deal of skill. Usually, it is far more economical to replace a truck rather than attempt repairing it. To remove or replace a truck, merely loosen the mainframe screws a turn or two. This will provide sufficient additional clearance between the two mainframe castings to allow the trucks to drop out. Retighten screws after replacing trucks. Should it be absolutely necessary to disassemble a truck, work over a shallow-sided box to prevent loss of parts and proceed as follows: Use tweezers to disengage the tiny latches at the ends of the truck frame. Entire truck can now be disassembled.