

N ALCO RS-3 DIESEL LOCO JAPAN

FIG. 1

Exploded Loco Assembly

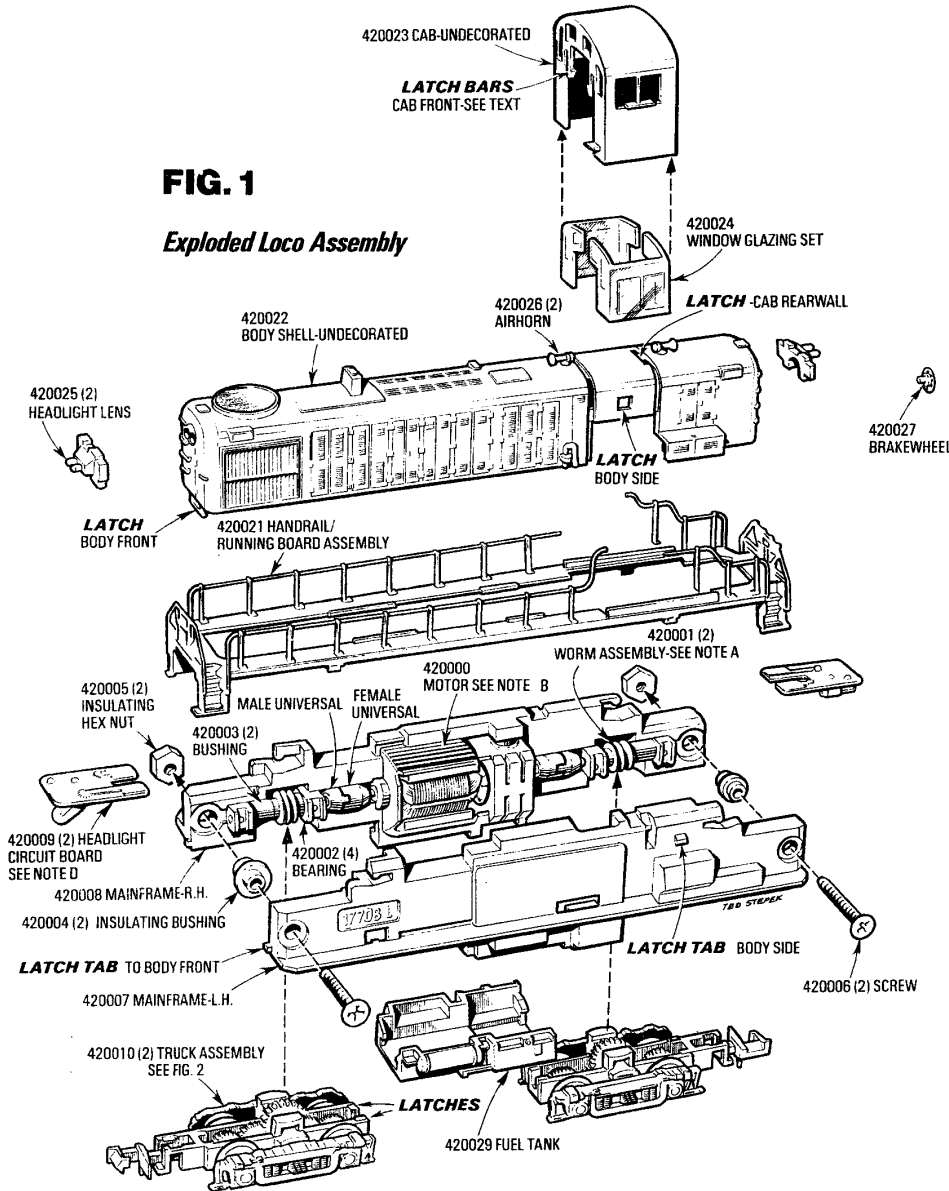

Mr. Roundhouse Superintendent:

The Atlas Alco RS-3 Diesel has been carefully assembled and tested before leaving the factory. It will provide virtually maintenance-free service; however, normal wear from extended usage may necessitate occasional replacement of lamps and motor brushes.

Major disassembly should rarely be necessary and *is not recommended* for the novice. Only a person experienced in the repair of miniature locomotives should attempt dismantling the model as shown in the exploded perspective drawings and described in the text.

IMPORTANT!

Before attempting any disassembly, all the instructions should be carefully read and the exploded perspectives studied thoroughly in order to become familiar with the several latch locations which are identified in the drawings in a bolder italic typeface, ie **LATCH**.

Also, it is not necessary to completely dismantle the Chassis in order to remove or replace the trucks. See "Truck Replacement" on reverse side.

BODY Removal

- 1) Disengage handrails from holes in cab walls.
- 2) Remove Cab by gently pressing against its rearwall and, simultaneously, gently wiggling the cab sideways. This will release the rear cab latch allowing cab to be lifted far enough to release cab front latch bars.
- 3) Remove loco body as follows: Notice that removing cab discloses a small, square hole in the body sidewall on each side. These holes engage a small tab, or boss, on the side of the mainframe castings. Use a jeweler's screwdriver, or the like, to *very gently* lever the body upward *only enough* to allow the battery boxes to clear the boxlike protuberance on the mainframe sidewalls. Now, slide the body shell *very slightly* forward to release the U-shaped body latch at the bottom of the frontwall. The body can now be lifted away. Also, the Railing/Running Board Unit can now be removed.

CHASSIS Disassembly

- 1) Remove both Headlight Circuit Boards by sliding them away from the mainframe castings.
- 2) Lay the mainframe on its rightside and remove the screw at each end. Carefully lift away the Left Mainframe to expose chassis elements. Be careful not to lose the #420004 Insulating Bushings separating the mainframe castings at each end.

NOTES

A) 420001 WORM ASSEMBLY includes Worm, Shaft, one 420002 Bearing Block, one 420003 Bushing and Male Universal Coupling.

B) 420000 MOTOR ASSEMBLY includes Female Universals on shaft ends

C) Numerals in parentheses indicate number required per loco if more than one

, 420009 HEADLIGHT CIRCUIT BOARD includes bulb and directional diode.

FIG. 2

Exploded Truck Assembly

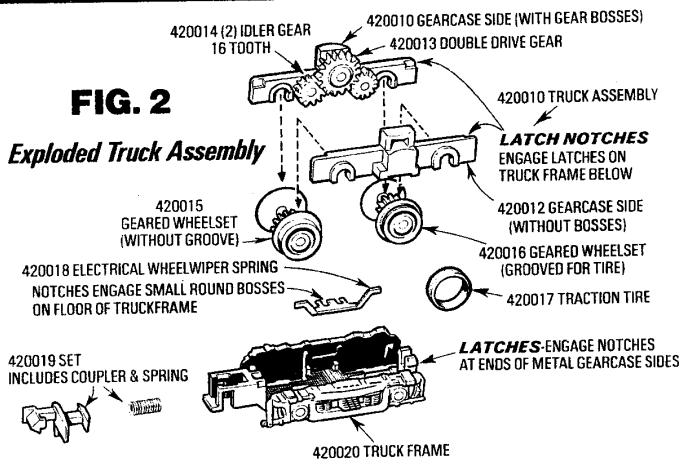

TRUCK Replacement

We recommend against attempting repairs to the trucks. Disassembly is relatively easy but reassembly is very difficult and requires a great deal of skill. Usually, it is far more economical to replace a truck rather than attempt repairing it. To remove or replace a truck, merely loosen the mainframe screws a turn or two. This will provide sufficient additional clearance between the two mainframe castings to allow the trucks to drop out. Retighten screws after replacing trucks. Should it be absolutely necessary to disassemble a truck, work over a shallow-sided box to prevent loss of parts and proceed as follows: Use tweezers to disengage the tiny latches at the end of the truck frame. Entire truck can now be disassembled.

