

HO EMD GP38/40 DIESEL LOCO (B) ROCO

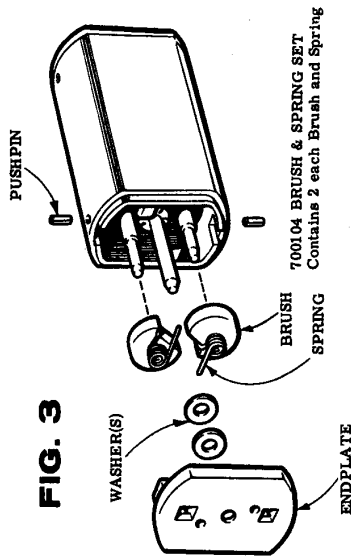

FIG. 3

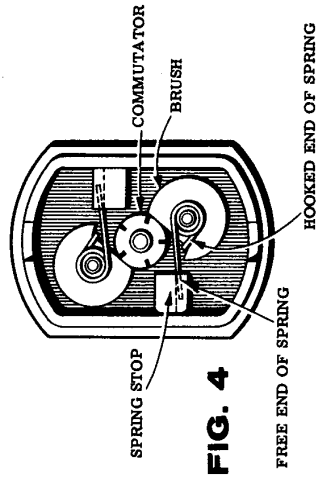
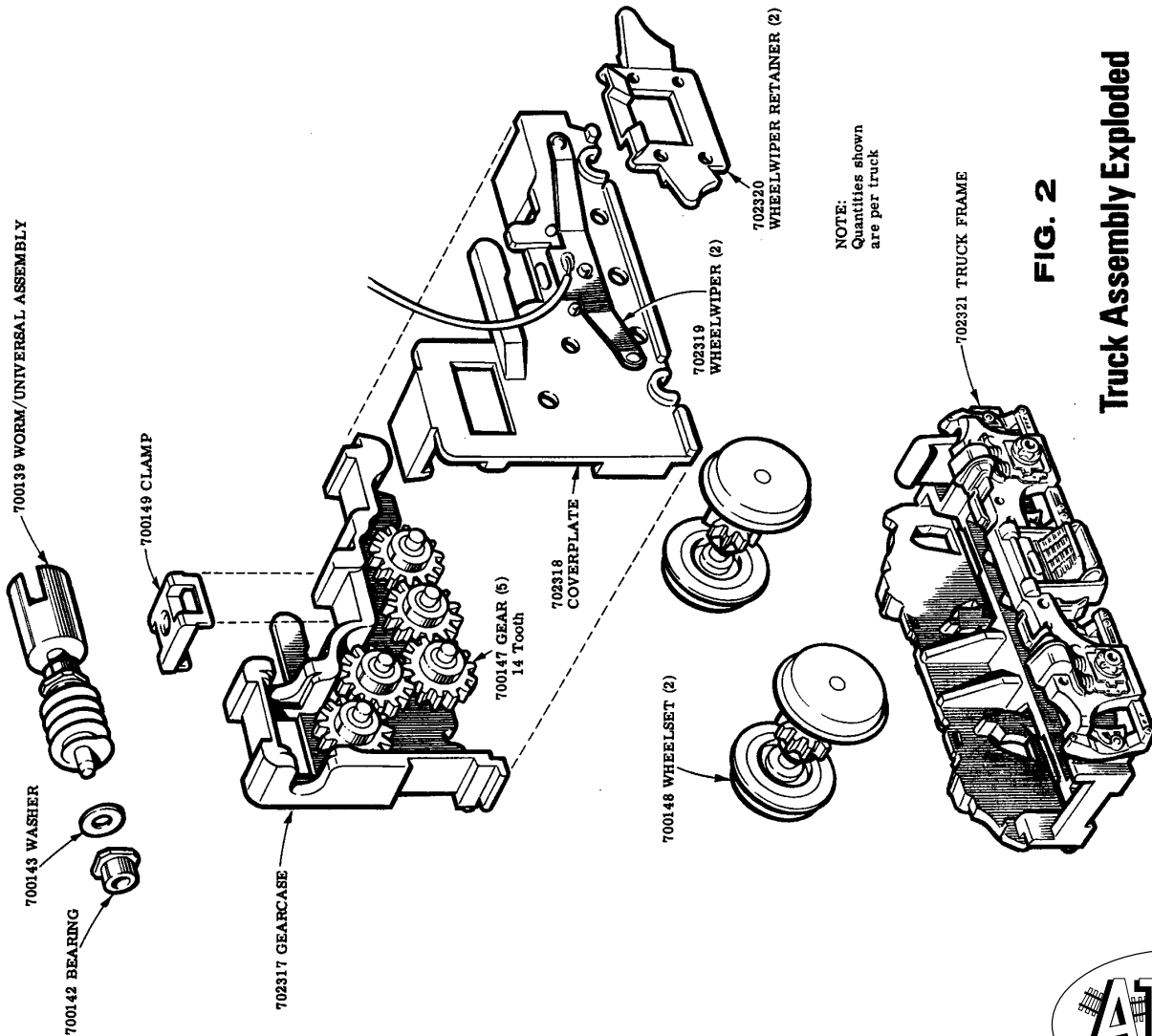

FIG. 4

Brush Replacement

Brush replacement requires that the motor endplate (see FIG. 3) be removed. This is accomplished in either of two ways:

- A. If the ends of the plate retaining pushpins can be seen through the two square apertures in the endplate, they can be pushed outwardly with the blade of a small screwdriver and then grasped with pliers and withdrawn.
 - B. If the pushpins cannot be seen through the endplate apertures they will then have to be removed by using a small diameter drift pin to push them into the apertures allowing them to be grasped with tweezers or a magnetized screwdriver blade. **IT IS VERY IMPORTANT** to capture the pin as described above so as to avoid unnecessary further disassembly of the motor. If the pins are pushed all the way through they may be drawn by the motor magnets into the motor's interior. Retrieving them will then require that the opposite endplate be removed and the armature withdrawn.
- Replacement brushes and springs must be arranged as shown in FIGS. 3 and 4. First install the brushes followed by the springs. Use a pointed tool to nudge the "hooked end" of the springs into engagement with the shouldered flat on the brush then, using the same tool, force the "free end" of the spring over the "spring stop" where it will be retained in a notch. Complete the re-assembly by replacing the small washers, endplate and pushpins. The motor will require several minutes of running to seat the new brushes before peak performance can be expected.



NOTE:
Quantities shown
are per truck

FIG. 2

Truck Assembly Exploded